

Contents

| | |
|---|----|
| General system information | 2 |
| Technical details | 3 |
| - Thermo E heating panels | 3 |
| - TR-A analogue regulator | 4 |
| Thermo E 400x600 with TR-A (overview) | 5 |
| Thermo E 500/600x1200 with TR-A (overview) | 6 |
| - TR-D digital regulator | 7 |
| Thermo E 400x600 with TR-D (overview) | 8 |
| Thermo E 500/600x1200 with TR-D (overview) | 9 |
| Thermo E with and without sensor | 10 |
| Installing Thermo E | 10 |
| Using the hook bar with Thermo E 500/600x1200 | 11 |
| Pressureless filling of the Thermo E 500/600x1200 | 12 |
| Laying, fastening and extending the cables | 13 |
| TR-A assembly / installation | 15 |
| TR-A operation and display | 16 |
| TR-D assembly / installation | 17 |
| TR-D operation and display | 18 |
| Setting the temperature | 22 |
| Guarantee | 23 |

General system information

- The Thermo E system is a special piglet nest heater and not a space heater since it warms the animals through body contact.
- The system should only be assembled and put into operation by qualified technicians and only within the framework of the technical guidelines. **MIK will assume no liability whatsoever for damage that results from improper usage or operation.**
- Only use MIK TR-A and MIK TR-D regulators to ensure that the equipment functions safely. **The guarantee will become void if the system is used in combination with any third party products.**
- The TR-A and TR-D regulators are to be used exclusively for operating MIK Thermo E panels.
- Protection class II is designated for the connection and the maximum power input is to be taken into consideration.
- **TR-A and TR-D regulators are designed to be connected to switch boxes and should only be connected, opened and repaired by qualified electricians.** The equipment is to be completely switched off before handling or opening the device!
- Always keep the lid of the protective housing of the TR-A/TR-D regulators closed to prevent the infiltration of moisture. Do not allow water to spray directly onto the housing when cleaning.
- The Thermo E electric panel can be cleaned using a high pressure cleaner (from an appropriate distance!). Do not use chemicals to clean the Thermo E surfaces. This applies especially to nitro-cellulose thinners and products which contain this or similar substances.
- TR-A and TR-D regulators do not need servicing. The surface of the device can be cleaned with a cloth.
- The water used to fill the Thermo E 500x1200 and Thermo E 600x1200 must not have anti-freeze or chemically similar active inhibitors (e.g. hydrazine, etc.) added to it. It must not contain any quantities of chlorine, fluorine or any other additives which cause an aggressive reaction with metals and seals.
- Thermo E 500x1200 and Thermo E 600x1200 panels need to be filled up with water before the system is operated. **The operation of non-filled panels is forbidden!** The temperature of the water used to fill the panels must not be less than 10°C.

If you have any queries or further questions about the system, please do not hesitate to call your MIK stockist or our customer service.

Technical details - Thermo E



Fig. 1: Thermo E 400x600mm



Fig. 2: Thermo E 500/600x1200mm

| Model | Thermo E 400x600 | Thermo E 500x1200 | Thermo E 600x1200 |
|---|--------------------------------|---|----------------------|
| Usable area | 400x600 mm | 500x1200 mm | 600x1200 mm |
| Max. power consumption (20°C ambient temp./40°C surface temp.) | approx. 85 W | approx. 178 W | approx. 208 W |
| Average consumption in the farrowing | approx. 60 W | approx. 150 W | approx. 175 W |
| Average consumption in the nursery | - | approx. 57 W | approx. 67 W |
| Water volume | - | approx. 25 l | approx. 30 l |
| Sensor cable | Ø 2 x 0.75 mm ² | | |
| Load cable | Ø 2 x 0.75 mm ² | Ø 3 x 1.5 mm ² | |
| Cable length | 6 m | 0.2 m (with standard splice connectors for extensions) | |
| Controller | with TR-A/TR-D regulators only | | |
| Protection type | IP 65 | | |
| Normal voltage | ~ 230 V / 50 Hz | | |

Technical details TR-A (analogue)

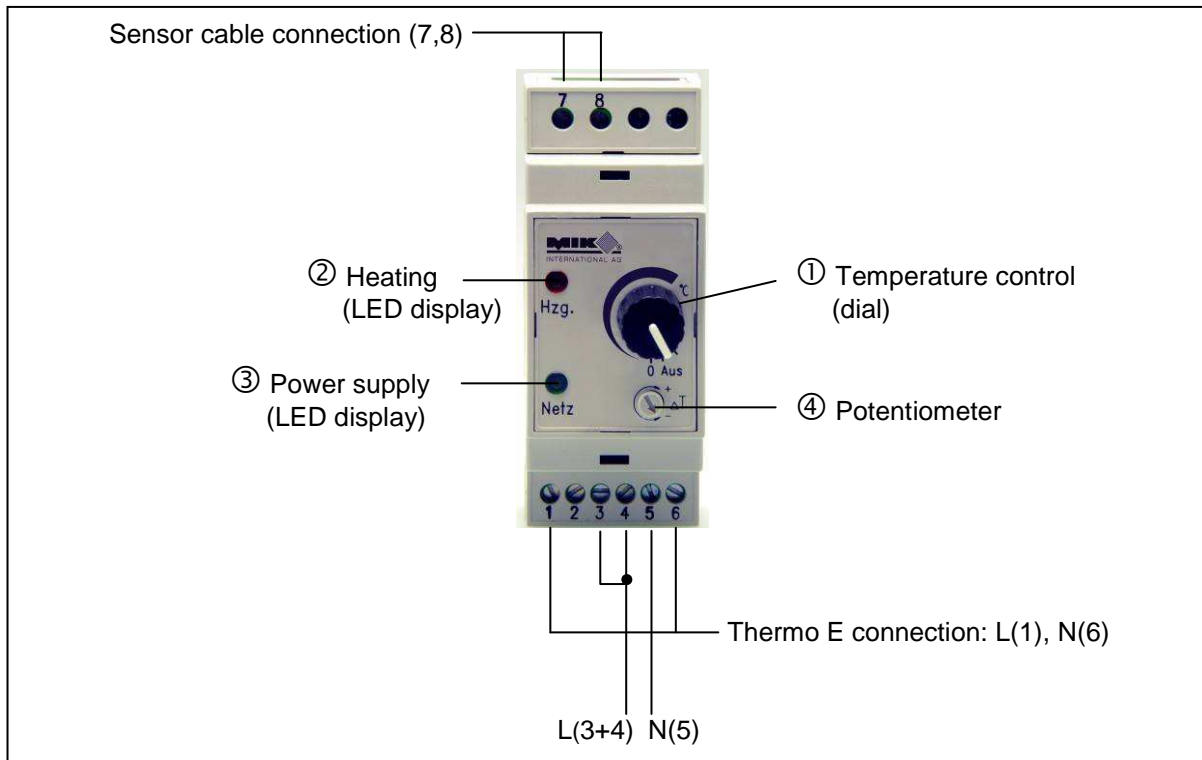

Fig. 3: TR-A regulator (1 channel heating controller)

| | |
|----------------------------------|---|
| Temperature range | 20°C to 50°C |
| Differential range | ± 0.25 to ± 2.5 K |
| Sensor | PTC 2k, polarity does not have to be taken into account |
| Operating voltage | 230 V AC (± 10%) |
| Power consumption | approx. 2.5 VA |
| Type of contact | two-way (relay contact, potential-free) |
| Max. permitted switching current | 8(2)A, 250 V AC at a maximum ambient temperature of +40°C: 10(3)A, 250 V AC |
| Connection | screw connectors |
| Permitted ambient temperature | -10°C to +50°C |
| Storage temperature | -10°C to +70°C |
| Casing: | Material plastic |
| | Protection system IP 20 |
| | Protection class II compliant with DIN EN 60730-1 (switch box installation) |
| | Width 35 x 90 x 75 mm (2 x machine width) |
| | Mounting on DIN rails |
| | Weight approx. 150 g |

MIK Thermo E 400x600mm with TR-A (overview)

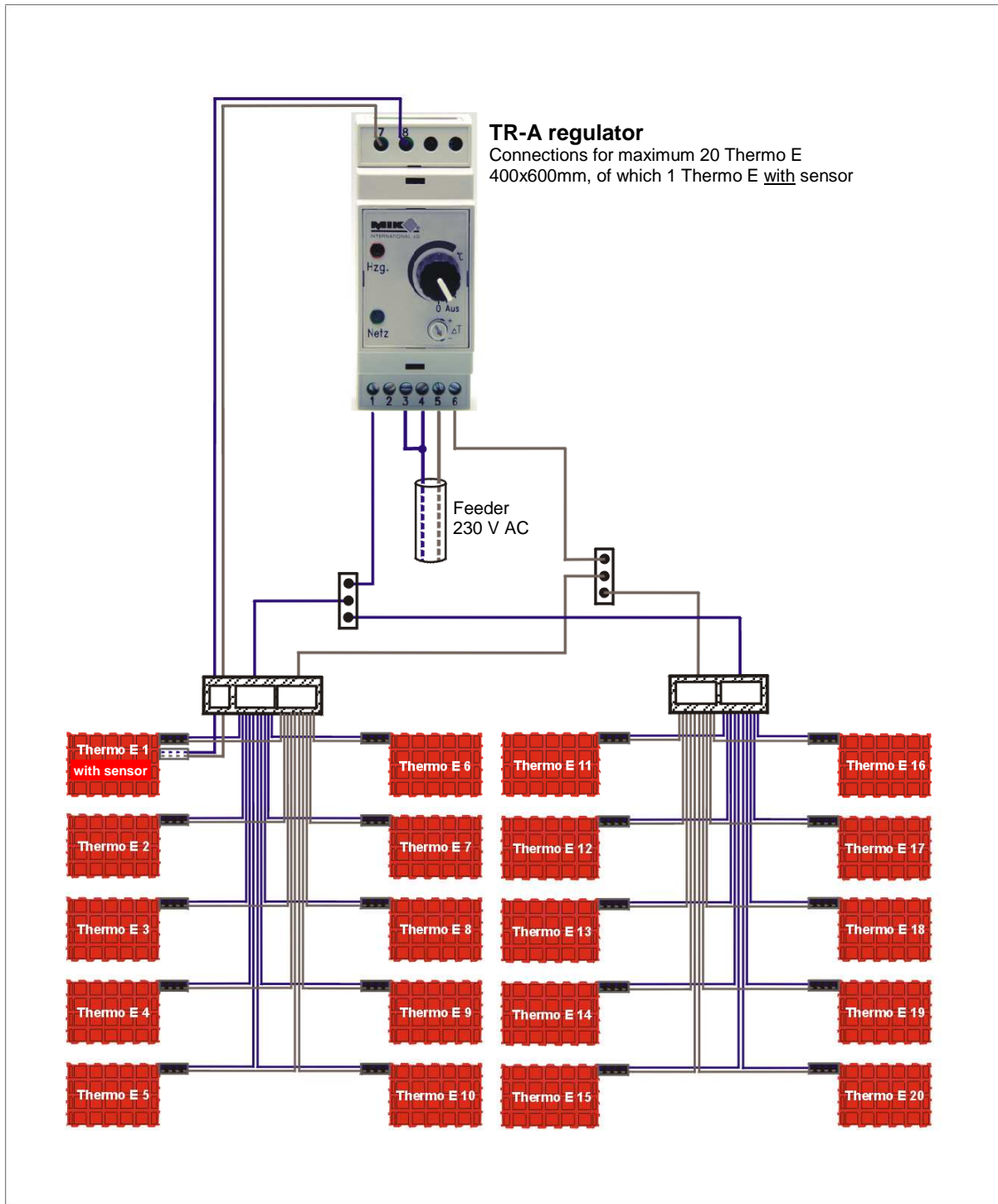

Fig. 4: Function diagram of the TR-A with Thermo E 400x600mm

MIK Thermo E 500/600x1200mm with TR-A (overview)

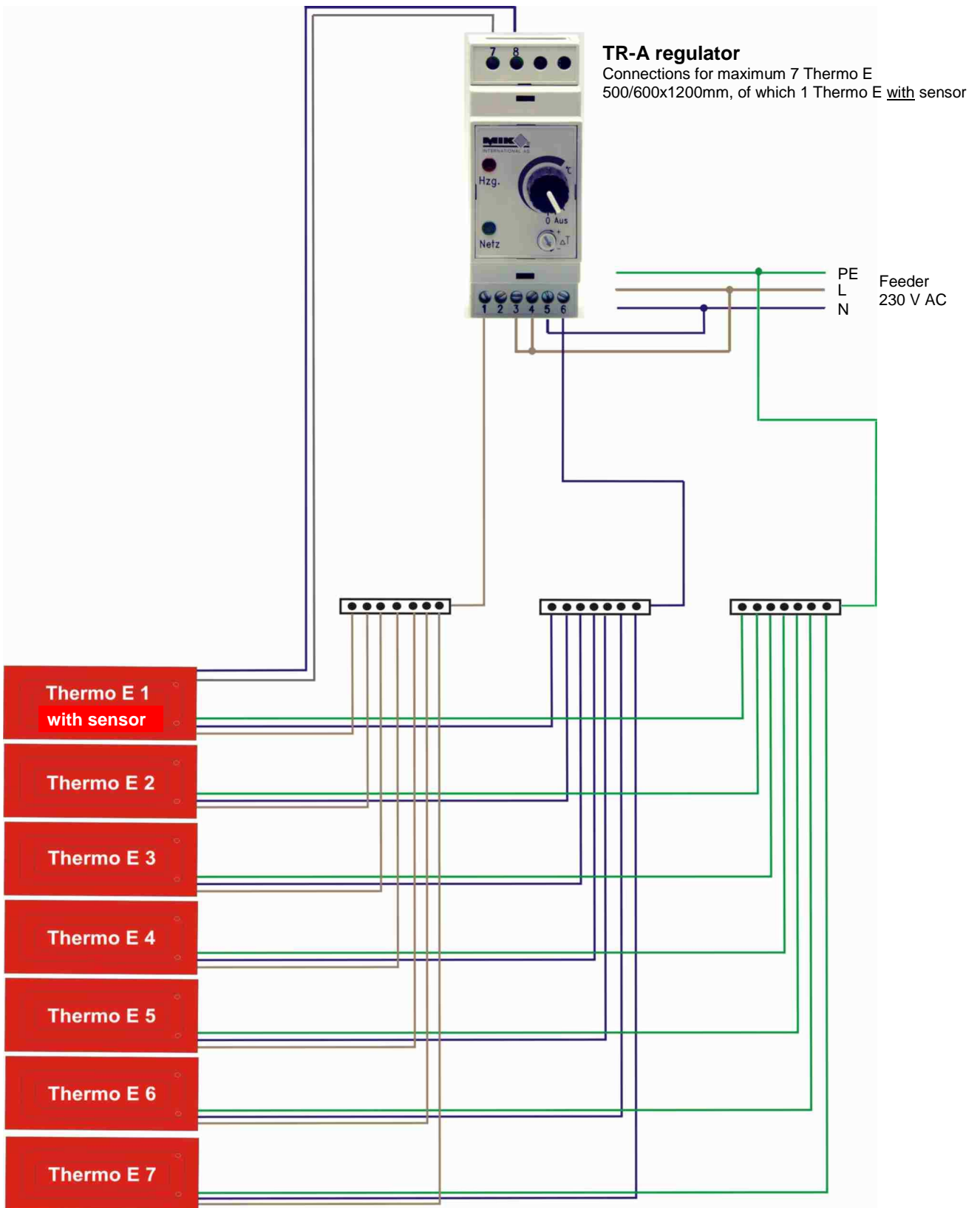

Fig. 5: Function diagram of the TR-A with Thermo E 500/600x1200mm

Technical details TR-D (digital)

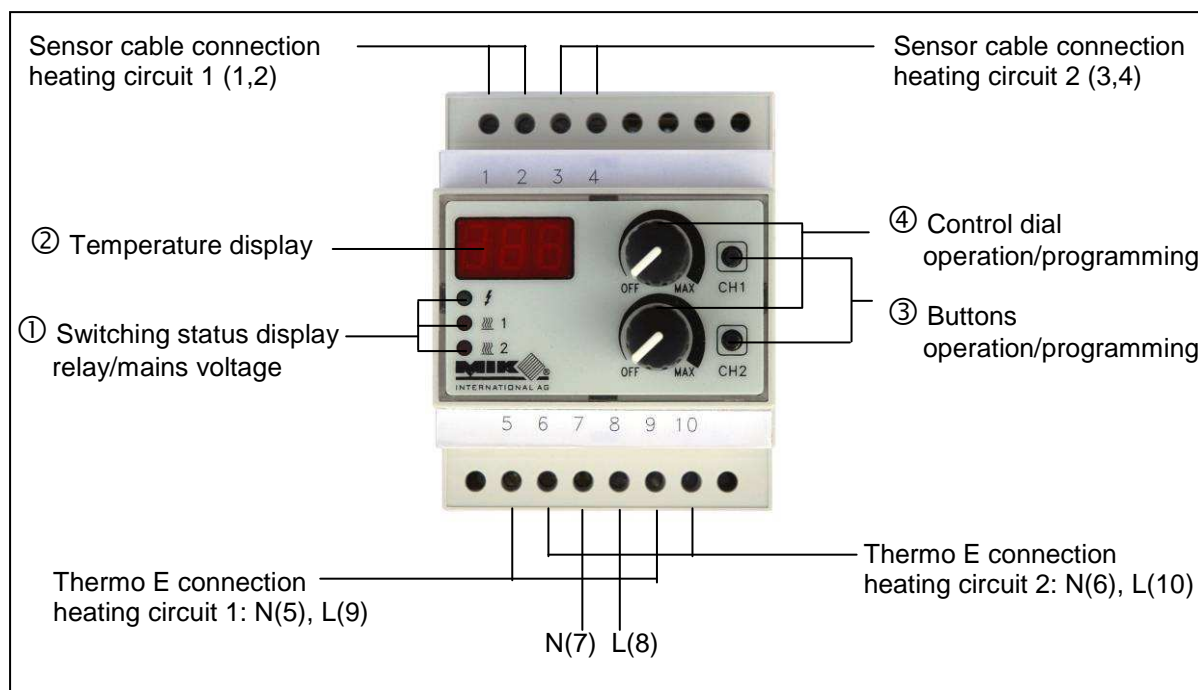

Fig. 6: TR-D regulator (2 channel heating controller)

| | |
|----------------------------------|---|
| Temperature range | 20°C to 50°C |
| Differential range | ± 0.2 K, fixed |
| Sensor | PTC 2k, polarity does not have to be taken into account |
| Operating voltage | 230 V AC (± 10%) |
| Power consumption | approx. 3 VA |
| Type of contact | relay, N/O contact, non-floating with L |
| Max. permitted switching current | per circuit/relay 8(2)A, 250 V AC cos-phi = 1, at a maximum ambient temperature of +40°C |
| Connection | screw connectors |
| Permitted ambient temperature | 0°C to +40°C |
| Storage temperature | -10°C to +70°C |
| Setpoint value adjustment | control dial resp. push-buttons |
| Programming | control dial and push-buttons |
| Visual indicator | LEDs for the switching status of the relay (red) and mains voltage (green), 3 digit display for temperature and programming |
| Casing: | |
| Material | plastic |
| Protection system | IP 20 |
| Protection class | II compliant with DIN EN 60730-1 (switch box installation) |
| Width | 70 x 90 x 75 mm (4 x machine width) |
| Mounting | on DIN rails |
| Weight | approx. 230 g |

MIK Thermo E 400x600mm with TR-D (overview)

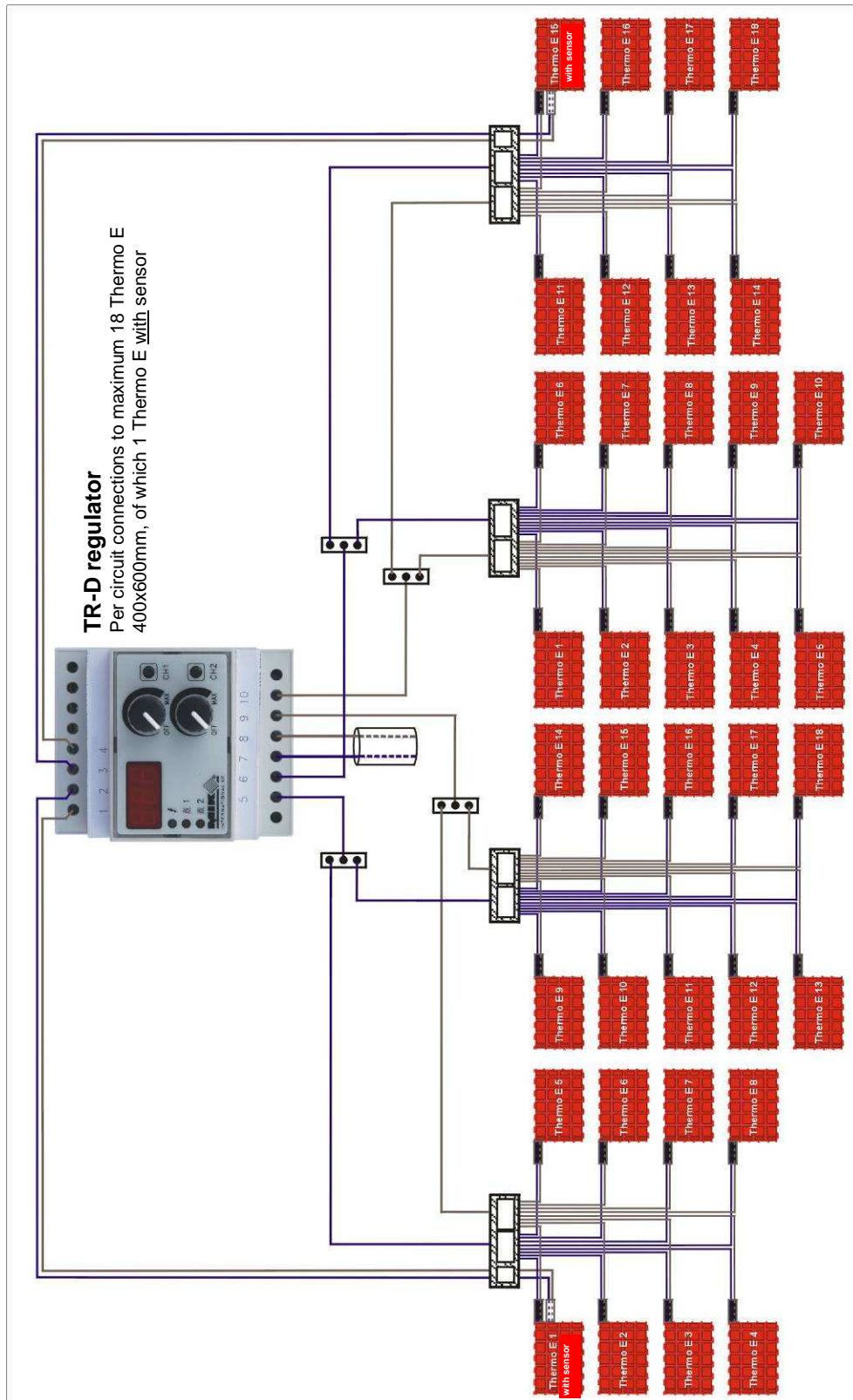

Fig. 7: Function diagram of the TR-D with Thermo E 400x600mm

MIK Thermo E 500/600x1200mm with TR-D (overview)

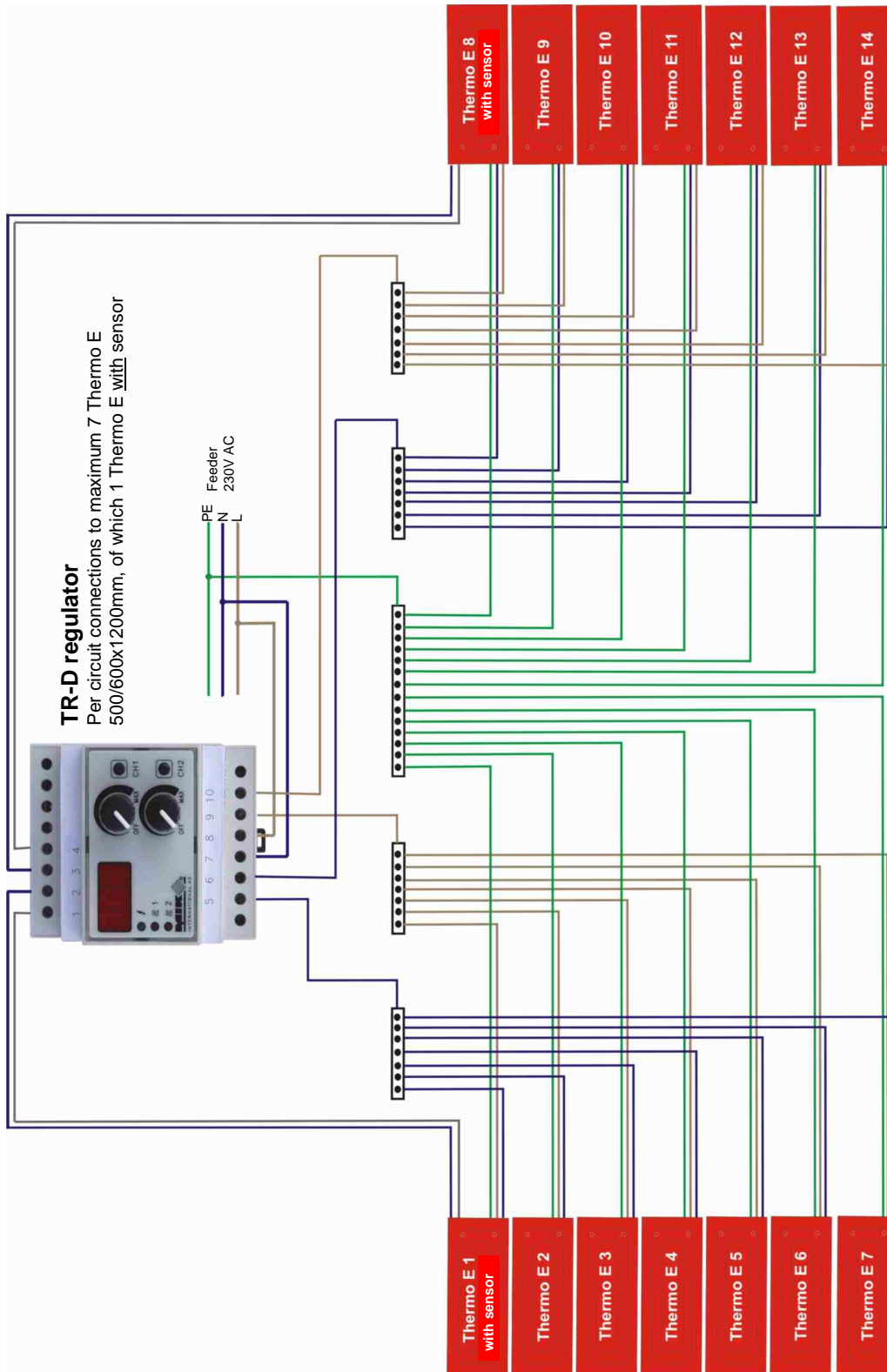

Fig. 8: Function diagram of the TR-D with Thermo E 500/600x1200mm

Thermo E with and without sensor

Thermo E panels are available in two designs – **with** and **without** temperature sensors. Each heating circuit must always include one Thermo E with a temperature sensor to allow use of the automatic temperature control function.

1. Multiple nest regulation

When using the TR-A regulator, 20 Thermo E 400x600 or 7 Thermo E 500/600x1200 panels can be connected to one circuit, one of which must have a sensor. This means that a total of 20 Thermo E 400x600 or 7 Thermo E 500/600x1200 panels can be regulated for each TR-A.

When using the TR-D regulator, 2 circuits can be connected each with a maximum of 18 Thermo E 400x600 or 7 Thermo E 500/600x1200 panels with one sensor for each circuit. This means that a total of 32 Thermo E 400x600 or 14 Thermo E 500/600x1200 panels can be regulated for each TR-D.

2. Single nest regulation

If single nest regulation is required, a control circuit must be provided for each warming nest and the appropriate number of regulators need to be installed. A single nest can be controlled with the TR-A single circuit regulator, and two single nests can be controlled individually using the TR-D double circuit regulator.

Installing Thermo E

MIK Thermo E heating panels are integrated in the MIK floor system flush with one another and seamlessly affixed to the respective beams (5mm thick). The supplied hook bars are used to do this with the models Thermo E 500x1200mm and Thermo E 600x1200mm. This means that all Thermo E panels are combinable row-wise with all the MIK plastic panels. They are laid in the same manner as all MIK panels, with the exception that the panels cannot be cut to shape. They can be post-installed in an existing floor system whenever required.

It is fundamentally possible to combine heating panels of different sizes. Due to their varying performance and switching characteristics (response behaviour when heating and cooling down), they do however have to be operated in separate heating circuits with their own sensor panel of the same model. It is not permitted to connect different Thermo E models to the same heating circuit!

Thermo E panels can be laid adjacent to one another or in series in a row. A gap of 10 cm should be left along the pen dividing wall to ensure a hygienic surface and optimum usage.

Farrowing:

MIK recommends laying three Thermo E 400x600 heating panels or respectively one Thermo E 500x1200 or Thermo E 600x1200 heating panel in each pen so that smaller or weaker animals will still have sufficient space on the heating surface. The nest is positioned outside of the sow standing area.

Nursery:

20-25% of the total pen floor area in the nursery should be foreseen as a heated area. The Thermo E panels can be laid in rows, or in an L or U shape with all-round perforation. An adequate gap must be left between the panels and pen dividing walls or feed and water troughs.

Using the hook bar with the Thermo E 500/600x1200

The hook bars are supplied together with the heating panel. We recommend using only the hook bars when laying the MIK Thermo E heating panels to ensure that they are securely fixed into place. The hook bars are installed when laying the panels. They are mounted on the beams in the panel framework using the toothed strip at the position where the Thermo E is to be laid. The design of the hook bar automatically determines the exact position of the heating panel with the aid of its centring tabs. Three hook bars are intended to be installed on each side. Two different hook bars are used with the MIK floor system. They are laid in the panel framework so that no gaps are left. Three hook bars have a total length of 1.2 m. A gap of approx. 10 mm is left between two heating panels when laying two or more Thermo E panels one after the other. This is intentional and is designed for expansion and cleaning purposes. The width of this gap is compliant with German animal welfare and livestock farming regulations (TierSchNutzTV).



Fig. 9: Hook bar for mounting the Thermo E panel on the beam



Fig. 10: Hook bar mounted on the beam in the panel framework

Pressureless filling of the Thermo E 500/600x1200



1. initial situation



2. open locking screw with included tool



3. lift the panel with the tool

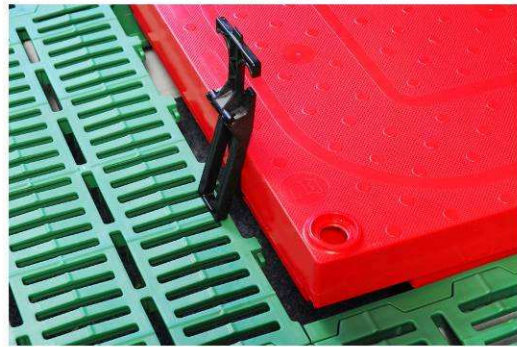

4. use tool as pedestal holding up the panel

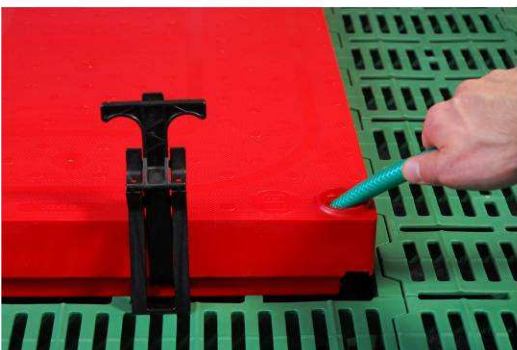

5. fill panel pressure-less with water hose



6. refasten locking screw



7. carefully set down panel



8. ready to start the heating system!

Fig. 11: Pressureless filling of the Thermo E 500/600x1200

Laying, fastening and extending the cables

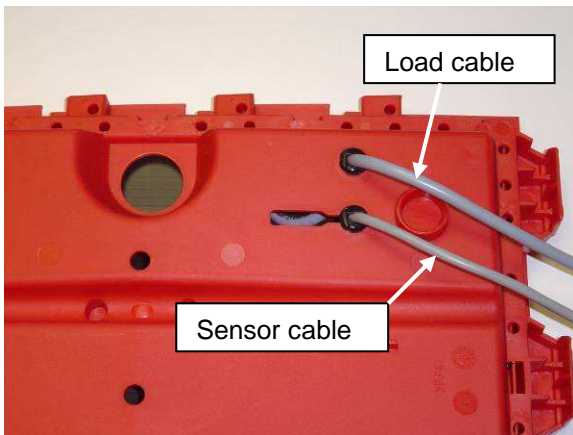

Fig. 12: Sensor and load cable on the Thermo E 400x600

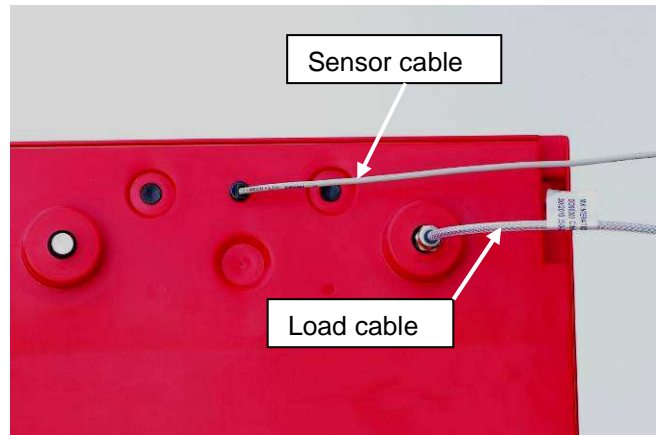

Fig. 13: Sensor and load cable on the Thermo E 500x1200 and Thermo E 600x1200

Thermo E heating panels are supplied with and without temperature sensors. Thermo E panels without a sensor are only fitted with one load cable on the underside. Thermo E panels with sensor are fitted with an additional sensor cable. The load cable is the thicker of the two cables and leads out of the round aperture at the edge (Thermo E 400x600) or out of the tube thread (Thermo E 500/600x1200). The thinner sensor cable leads out of the panel body through a separate aperture.

The cable is laid and fastened into place underneath the plastic framework. The cables can be affixed to the beams using cable ties (see Fig. 14). Protective tubing can also be used for laying the cables. These should be sealed at the ends to prevent the infiltration of rodents and accumulation of dirt.

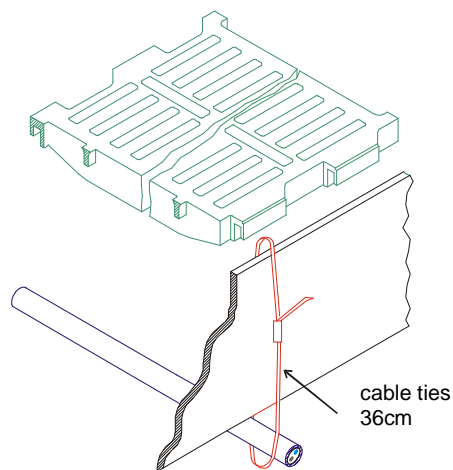
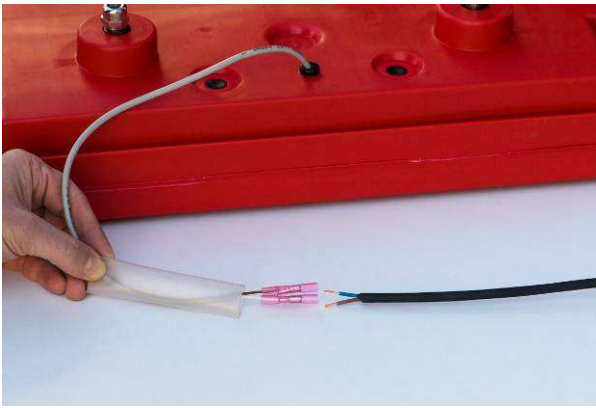

Fig. 14: Fastening the cable to the beam

The cable must also be laid in protective tubing along the wall leading out of the room to keep them out of reach of the animals.

Project-specific extensions to sensor and load cables must comply with protection class IP 65. Thermo E 500x1200 and Thermo E 600x1200 panels are equipped as standard with appropriate splice connectors for this purpose. Shrink tubing, which offers extra protection

at the joints, is also supplied with these heating panels. The procedure is demonstrated below using the example of extending the sensor cable of a Thermo E 500x1200 panel:



1) Strip the strands of the extension cable to fit the splice connectors and pull the shrink tubing over the panel connection cable.

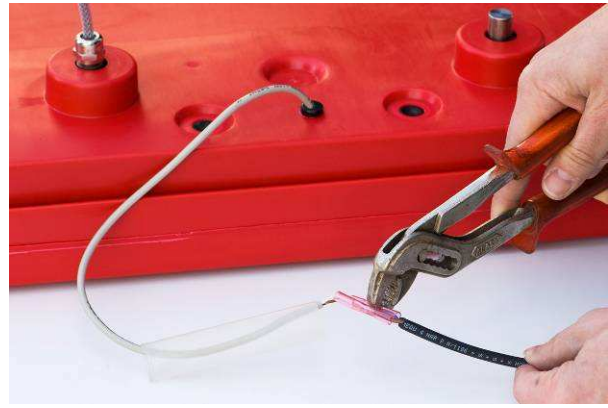

2) Firmly squeeze the strands of the extension cable into the extension end of the splice connectors using pliers.

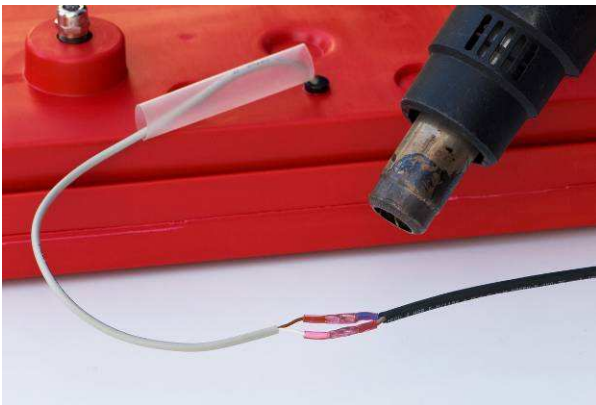

3) Now shrink-wrap the splice connectors onto the cables on both sides using a hot-air blower.

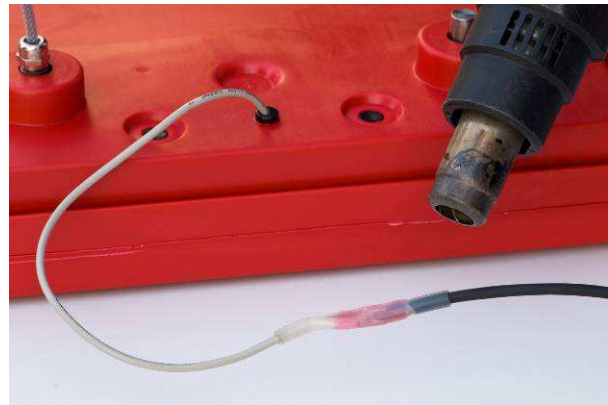

4) Finally, slide the shrink tubing over the joint and use the hot-air blower to shrink-wrap the cable starting in the middle and working your way to the ends – finished!

Fig. 15: Extending the panel connection cable

According to the European standard EN 60335-2-71, mains connection cables are not allowed to be lighter than conventional cables with polychloroprene sheathing. Usage of the cable type H05RN-F ensures compliance with this standard.

In practice, so-called H05VV5-F, H03VV-F & LiYY-ÖW "Ölflex" cables have also proved effective for extending (sensor) cables. The cross-section of the extension cables should not be less than that of the fitted connection cables (cf. "Technical details" on page 3).

Sensor and load cables must always be extended using separate cables!

This means that the current and sensor conductors must not be combined in a multi-conductor cable.

TR-A assembly / installation

General: The assembly may only be carried out by an electrician!

Sensor connection: The temperature sensor is connected to two terminals.
The polarity does not have to be taken into account.
The maximum permitted cable length is 100 m at 1.5 mm² Cu.

Assembly

- The device is mounted in the terminal box.
- Disconnect the wiring from the power supply before working on the device!
- The device is connected as shown in the basic circuit diagram below (see also Fig. 3):

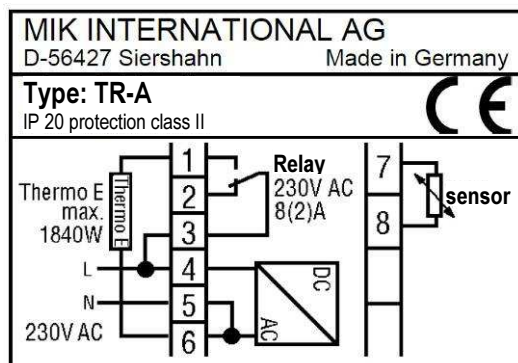

Fig. 16: TR-A basic circuit diagram

- The device is only designed to be connected to fixed installation cabling.
- When installing the device, make sure that mains voltage wiring such as the power supply cable and relay connection cables does not come into contact with low voltage wiring like sensor cables (minimum distance of 4 mm for basic insulated conductors).
- It must also be ensured that all the connection cables are adequately secured against working their way loose in compliance with the provisions of EN 60730, Part 1. This can be achieved by securing the wiring into place using cable ties, for example.
- VDE 0100 (in particular Part 705), EN 60730, Part 1, as well as the local public utility regulations are to be observed.
- The sensor cables should not be laid adjacent to other current-carrying wiring to avoid any interference.
- The device is to be protected by an automatic cutout switch rated at max. 10 A.
- The connection cables must be laid out of reach of the animals.
- Connection cables that are laid directly in concrete flooring must be protected (empty conduit).
- Current-carrying wiring (L and N) is not to be looped from device to device, but must be laid separately from a bus bar. This also applies to the protective conductor (PE) when installing Thermo E 500/600x1200 panels.
- If the device does not function, make sure that the cables are connected correctly and check the power supply.

TR-A operation and display

The required temperature can be set using the control dial ① (see Fig. 3). The illustration shown here is for general orientation. The device is switched off by turning the control dial anti-clockwise to the "OFF" position.

The switch differential can be set with a control dial ④ using a flat-head screwdriver.

A green LED lamp ③ indicates that the power supply is in order and that the sensor is functioning correctly. If the green LED does not light up, this could mean that there is something wrong with the power supply or that the sensor is defective. The relay is switched off if the sensor is defective. The red LED lamp ② shows the heating mode.

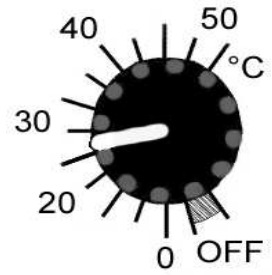

TR-D assembly / installation

General: The assembly may only be carried out by an electrician!

Sensor connection: The temperature sensor is connected to two terminals respectively.
The polarity does not have to be taken into account.
The maximum permitted cable length is 100 m at 1.5 mm² Cu.

Assembly

- The device is only designed to be installed in terminal boxes.
- Disconnect the wiring from the power supply before working on the device!
- The device is connected as shown in the basic circuit diagram below (see also Fig. 6):

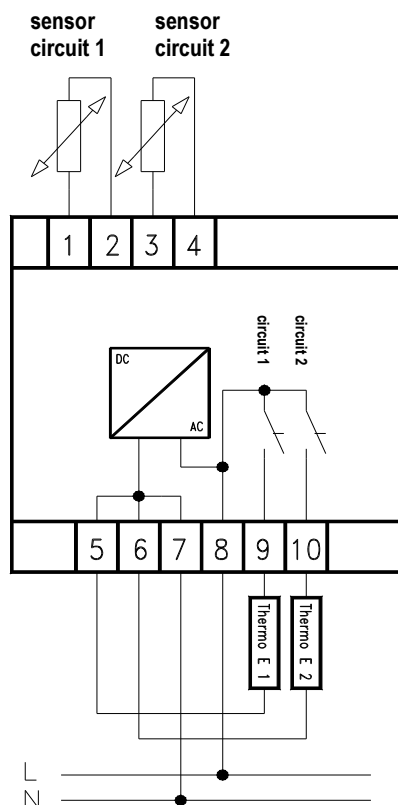

Fig. 17: TR-D basic circuit diagram

- The device is only designed to be connected to fixed installation cabling.
- When installing the device, make sure that mains voltage wiring such as the power supply cable and relay connection cables does not come into contact with low voltage wiring like sensor cables (minimum distance of 4 mm for basic insulated conductors).
- It must also be ensured that all the connection cables are adequately secured against working their way loose in compliance with the provisions of EN 60730, Part 1. This can be achieved by securing the wiring into place using cable ties, for example.
- VDE 0100 (in particular Part 705), EN 60730, Part 1, as well as the local public utility regulations are to be observed.
- The sensor cables should not be laid adjacent to other current-carrying wiring to avoid any interference. **Important - the sensor cables must not be wound around the relay connection cables!**

- The device is to be protected by an automatic cutout switch rated at max. 16 A.
- The connection cables must be laid out of reach of the animals.
- Connection cables that are laid directly in concrete flooring must be protected (empty conduit).
- Current-carrying wiring (L and N) is not to be looped from device to device, but must be laid separately from a bus bar. This also applies to the protective conductor (PE) when installing Thermo E 500/600x1200 panels.
- If the device does not function, make sure that the cables are connected correctly and check the power supply.

TR-D operation and display

Two independent control circuits are integrated in the TR-D, each of which records the actual temperature with a separate sensor and then adjusts the setpoint temperature in line with the settings.

Function

The device can be operated in two different modes depending upon the task in hand. "Normal mode" is for continuously controlling a constant setpoint temperature, whereas "Heating curve mode" is used to adjust the setpoint temperature in line with a growth cycle.

Depending upon the operating mode, the setpoint values are either set directly using the control dial or determined by the programmed heating curve.

The actual temperatures are indicated for each control circuit in turn on a three-line display for about 8 seconds. The LED of the respective control circuit flashes when its temperature is displayed.

The switch status of the relay is indicated by a red LED on the device (LED on = relay is switched on). *Which operating mode is currently selected is also shown on the display.*

"Normal mode" operation

In "Normal mode", the device functions as a two-position controller with a variable setpoint value. The setpoint value is set using the respective control dial and does not have a time limit. The required values are set on a notional scale between 20°C and 50°C. The current setpoint value is shown on the display while it is being set. The actual value is shown again after about 3 seconds. The setpoint value can also be displayed by briefly pressing the **CHx** button (CH1 for control circuit 1, CH2 for control circuit 2).

The green LED flashes when a setpoint value is being displayed! The corresponding red LED lights up constantly at the same time to indicate the respective control circuit to which the value belongs.

The respective control circuit is switched off by turning the control dial to the "OFF" position. "OFF" is then shown on the display after a short time instead of the actual temperature.

A control circuit can only be fully deactivated in "Normal mode".

The control circuits are switched from "Normal mode" to "Heating curve mode" by pressing the **CHx** button for approx. 5 seconds. The device is reverted to "Normal mode" in the same way.

"Heating curve mode" operation

In "Heating curve mode", the setpoint value (beginning with a start temperature, e.g. 38°C) is run down over a predefined period of time to an end temperature (e.g. 30°C). This is done by programming the parameters "tS.." (start temperature), "tE.." (end temperature) and "hr.." (duration in hours per 1°C reduction in the setpoint value) in the device. When the device is switched from "Normal mode" to "Heating curve mode", the timer is stopped and the parameter "tE.." stipulates the end temperature (*this must be checked!*). A decimal point now lights up continuously in the bottom right corner of the display. This signals that the timer has stopped. A quick press (approx. 1s) of the **CHx**³ button briefly displays the setpoint value – "tS.." – and the timer is started. The start temperature is determined by the parameter "tS.." and the decimal point flashes in the segment on the right. The operation is stopped again with another press of the **CHx** button. This resets the timer and the setpoint value – *this is displayed briefly* – is set to "tE..". The decimal point lights up again continuously.



The current setpoint value for a heating curve can be changed while the programme is running. The new setpoint temperature is simply selected for the appropriate heating circuit using the control dial.

The previously configured setpoint value is shown on the display until the control dial setting corresponds to this value.

The setpoint value can be changed if these two values match. Once the required value has been set, it is automatically taken over within a few seconds and becomes the valid setting. The actual temperature is displayed again. The timer is not interrupted as a result. When the heating curve has been completed, the manual correction of the setpoint value is deleted again and the saved values apply without any restriction.

To check the current setpoint value during an active heating curve, it can be shown on the display by briefly (< 1s) pressing the **CHx** button. After a few seconds the display reverts back to an actual value.

The green LED flashes when a setpoint value is being displayed! The red LED for the respectively selected output lights up continuously. This indicates that a setpoint value is being displayed and which one it is.

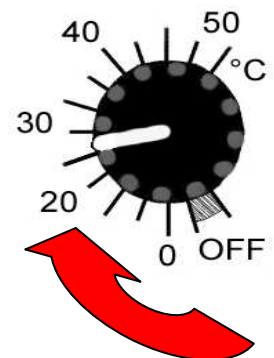

Once the heating curve has started, the setting "tS.." applies as the setpoint value. The parameter "hr.." now determines after how many hours (setting 1-99) the setpoint value is to be reduced by 1K. The duration of the heating curve is calculated from the difference in temperature between "tS.." and "tE.." and the interval "hr..". Here is an example:

"tS.." = 32°C, "tE.." = 25°C, "hr.." = 24 (h/K)

$32^{\circ}\text{C} - 25^{\circ}\text{C} = 7\text{K} * 24\text{h/K} = 168\text{h}$ (7 days). The setpoint temperature "tE.." is attained after a runtime of 168 hours and the heating curve has then been completed. The process is controlled without any time limit according to the value "tE.." (25°C).

Programming the heating curve

The parameters for the heating curve are programmed in a submenu. This is opened by pressing the CH1 and CH2 buttons simultaneously for approx. 5 seconds. In the submenu, the control dial for the 2nd control circuit can be used to "scroll" through the various parameters. A press on CH2 shows the parameter value. To change this, slowly turn the control dial around the notional scale range. If the saved and set values match, the set value is "captured" and can now be changed. The required setting is saved by pressing CH2 once more and the parameter list is displayed again. This allows the required values to be set one after the other. The submenu is closed by selecting "End" and pressing CH2 and the device switches to the previous operating mode.

An active heating curve cannot be changed and is not interrupted by opening the submenu.

The illustration below shows the submenu and the values "behind" the parameters. You always switch between the parameter and the value by pressing the CH2 button. The values are set using the control dial for the 2nd control circuit.

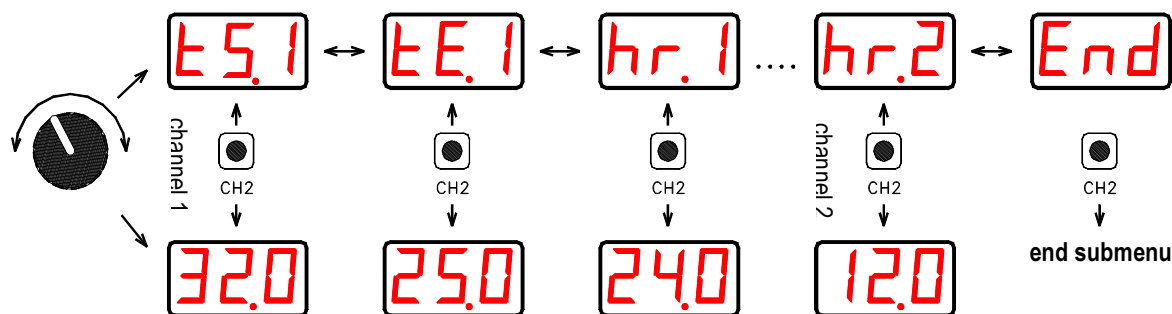

Note that the programmed start value must always be higher than the end value. The time cannot be started if the values have not been programmed correctly (tS.. <= tE..). The process continues to be controlled according to the value tE...

The programming is aborted in the event of a lengthy pause (approx. 3 minutes). Unconfirmed values are rejected.

Functionality after putting into operation or restoration of power

The "Normal" and "Heating curve" operating modes are saved. After power has been restored, the most recent operating mode is called up and applied as follows:

"Normal mode": The process is controlled according to the configured setpoint value

(control dial setting); this also includes the "OFF" setting!

"Heating curve mode": The timer is stopped; the process is controlled according to the setpoint value for the parameter "**tE..**".

Optical display

A red LED for each output indicates the switch status of the relays. A green LED shows the operational readiness of the device. A 3-line display is integrated in the device for showing the setpoint and actual temperatures, help texts for programming, and status reports. The respective LED flashes briefly to allow the displayed temperature to be matched with the corresponding heating circuit. The displayed actual values (sensor) are shown alternately for approx. 8 seconds.

Sensor monitoring

Both sensor inputs are monitored for short circuits or breaks. If the device detects a defective sensor, the corresponding output is deactivated. "**Err**" is then shown on the display instead of the actual value. The limits for troubleshooting are temperatures $> 80^{\circ}\text{C}$ and $< -20^{\circ}\text{C}$.

Output

The device has one relay output (N/O contact) per channel. This is lead through to the respective terminal with applied voltage (with L). See "Technical details" for the maximum load. The device does not have an internal fuse. The operator must ensure that it is properly protected.

Supply voltage

The device is designed to be operated with 230V/50Hz AC voltage. It does not have an ON/OFF power switch. It is designed to be connected only to fixed installation wiring.

Setting the temperature

Fluctuations in the temperature of the Thermo W panel are caused by the prone positions adopted by the piglets. As the temperature needs of the piglets cannot be determined by the age of the animals, their prone positions must be observed and the temperatures set accordingly (Fig. 18).

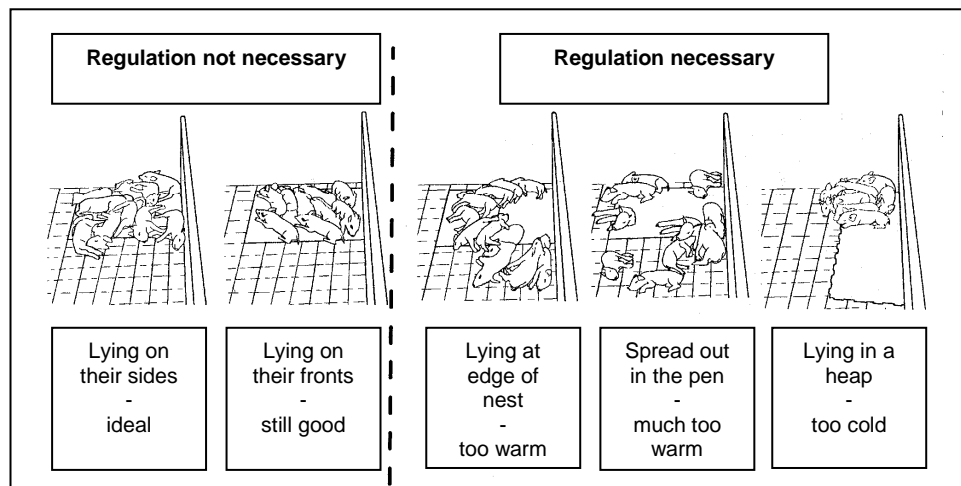

Fig. 18: Prone positions of piglets and heating requirements at different temperatures

At birth, the surface temperature of the Thermo W panel should be set at between approx. 38°C - 41°C. The piglets should lie either on their sides or their fronts. During the first one or two days, an infra red heating element can be additionally installed over the piglet nest as the animals need a great deal of warmth at this time.

Guarantee

MIK INTERNATIONAL AG grants a manufacturer's guarantee of 2 years from the delivery date. During this time, MIK INTERNATIONAL AG guarantees that the system will function properly (comprising MIK Thermo E heating panels with and without sensor, MIK TR-A and/or MIK TR-D) as well as free repairs by the manufacturer in the event of any defect for which we are responsible.

Guarantee claims will be declared void in the following situations:

- Improper usage of the system
- Improper assembly, especially if carried out by non-franchise contract installation companies
- Usage of regulation units other than MIK TR-A/MIK TR-D or other system components
- Unauthorised operation
- Continuing to operate defective pieces of equipment
- Unauthorised alterations to the system
- Interference by third parties and uncontrollable acts of nature
- Improper cleaning
- Combination with components from other manufacturers

Guarantee claims only apply to the system described above. Further claims for compensation are excluded.

Our general business conditions apply and can be viewed at www.mik-online.de or requested from MIK INTERNATIONAL AG.

The processing of warranty claims is subject to the disassembly and return transportation of the part or parts to the manufacturer. Only complete returned parts can be considered. Returned parts should be put in the original or equivalent packaging for transportation. MIK will not take over these tasks or install the repaired part or parts.